

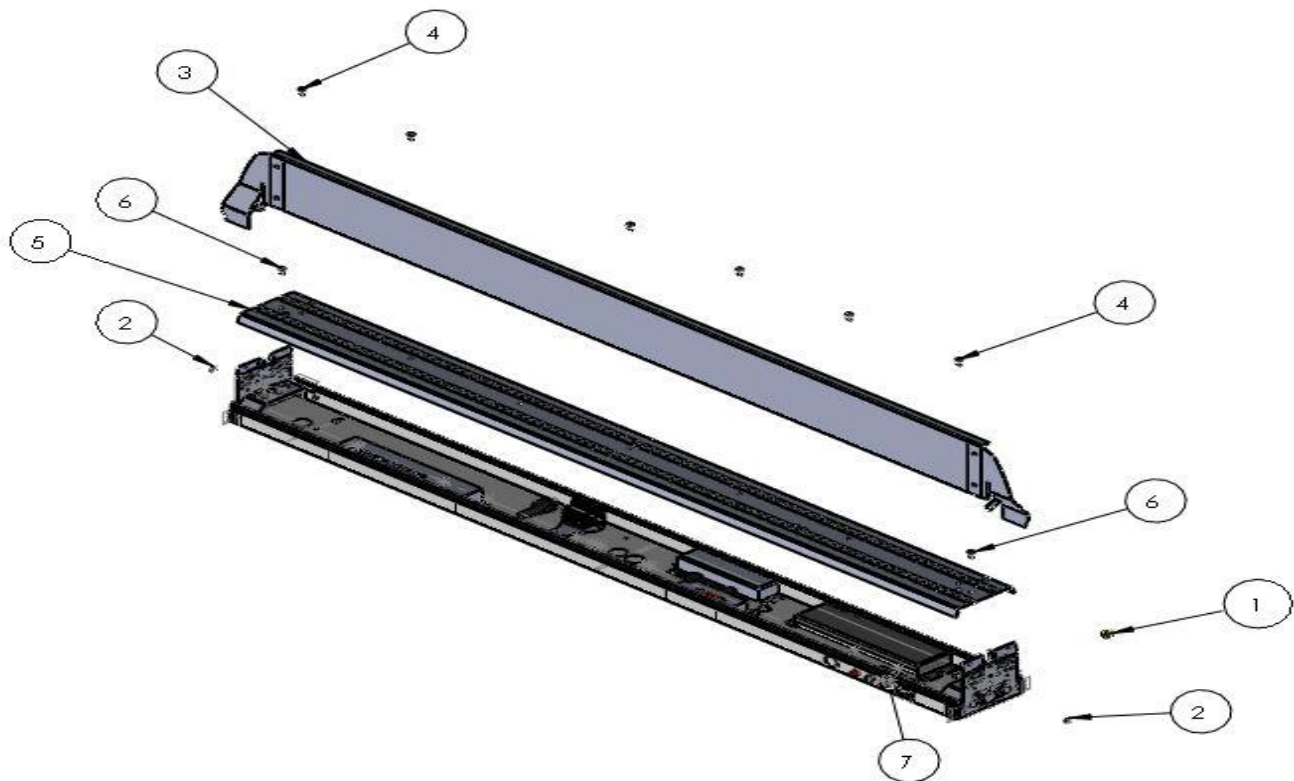

**INSTALLATION & MAINTENANCE INSTRUCTIONS
FOR THE
Dunbar – LED
Wall Mounted Luminaire P.N.:76105 REV.1**

WARNING: DISCONNECT POWER PRIOR TO INSTALLATION OR SERVICING OF FIXTURE

NOTE: THIS PRODUCT MUST BE INSTALLED IN ACCORDANCE WITH THE APPLICABLE LOCAL & NATIONAL ELECTRICAL CODES BY A PERSON FAMILIAR WITH THE CONSTRUCTION AND FAMILIAR WITH THE OPERATION OF THE PRODUCT AND HAZARDS INVOLVED.



INSTALLATION

1. Cut power to circuit.
2. Remove both thumb screws (Item 1) and lens.
3. Unscrew #8-32 nut (Item 2) on both ends to remove baffle assembly (Item 3). Also remove the #8-32 screws (item 4) securing the baffle to the reflector (item 5). If no baffle is included, unscrew #8-32 screws from front of reflector (Item 6) then remove.
4. Fasten mount pan (Item 7) to mount surface with four fasteners supplied by customer, or with supplied mount kit (optional).

5. Connect the luminaire's neutral (white), ground (green or bare), and power (black) wires to the supply circuit wires within the mount pan (Item 7).
6. Replace reflector (Item 5) then fasten with #8-32 on the front (Item 6).
7. Replace baffle assembly if equipped (Item 3) and fasten with #8-32 nuts (Item 4) on both ends
8. Replace lens and thumb screws (Item 1).
9. Restore power to circuit.

MAINTENANCE

DO NOT use cleansers containing bleach.

The metal portion of the fixture can be wiped clean as needed using a mild soap solution.

ATTENTION: *Avoid moving any exposed wires. If any wires are accidentally disconnected, call a professional to repair.*

