

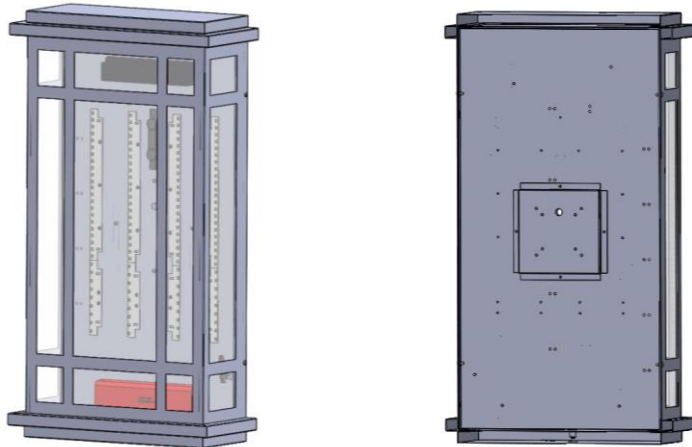

**INSTALLATION & MAINTENANCE INSTRUCTIONS
FOR THE
FALDO XL - LED
OUTDOOR STRIPS**

NOTE: THIS PRODUCT MUST BE INSTALLED IN ACCORDANCE WITH THE APPLICABLE LOCAL & NATIONAL ELECTRICAL CODES BY A PERSON FAMILIAR WITH THE CONSTRUCTION AND FAMILIAR WITH THE OPERATION OF THE PRODUCT AND HAZARDS INVOLVED.



INSTALLATION

1. *Make sure the power to the area working in is shut off to avoid serious injury from electrical shock.*
2. *To prevent high voltage from being present on yellow & yellow/black output leads prior to installation, converter connector must be open. Do not join converter connector until installation is complete and AC power is supplied to the emergency driver.*
3. *Remove any excess packing from the fixture.*
4. *This fixture is designed to be mounted to a 4" junction box (supplied by customer) and directly to wall with anchors. Open the housing assembly by removing the (4) 8-32 x 5/16" pan head screws located on both sides of the fixture.*
5. *Remove the (4) 8-32 x 1/4" screws holding the LED assembly plate to the mounting bracket.*
6. *Line up the back of the mounting bracket in desired location, completely covering the junction box and mount securely to the wall with 4 suitable fasteners supplied by the customer.*
7. *Complete the wiring to the power source and ground. The black as line; white as common; bare/green as ground. Wire connections to be made inside of housing.*
8. *Reassemble the LED board assembly back on to the mounting bracket with the (4) 8-32 x 1/4" screws.*
9. *Reassemble the housing to the mount with the (4) 8-32 X 5/16" pan head screws.*
10. *Outdoor wall fixtures must be caulked with a suitable, waterproof sealant across the top and at least "half way" down each side of the fixture to properly seal it to the mounting surface. A small space should be open at the bottom for excess moisture runoff.*

MAINTENANCE

The fixture can be wiped clean as needed using a mild soap solution.

ATTENTION: Avoid moving any exposed wires. If any wires are accidentally disconnected, call a professional to repair.

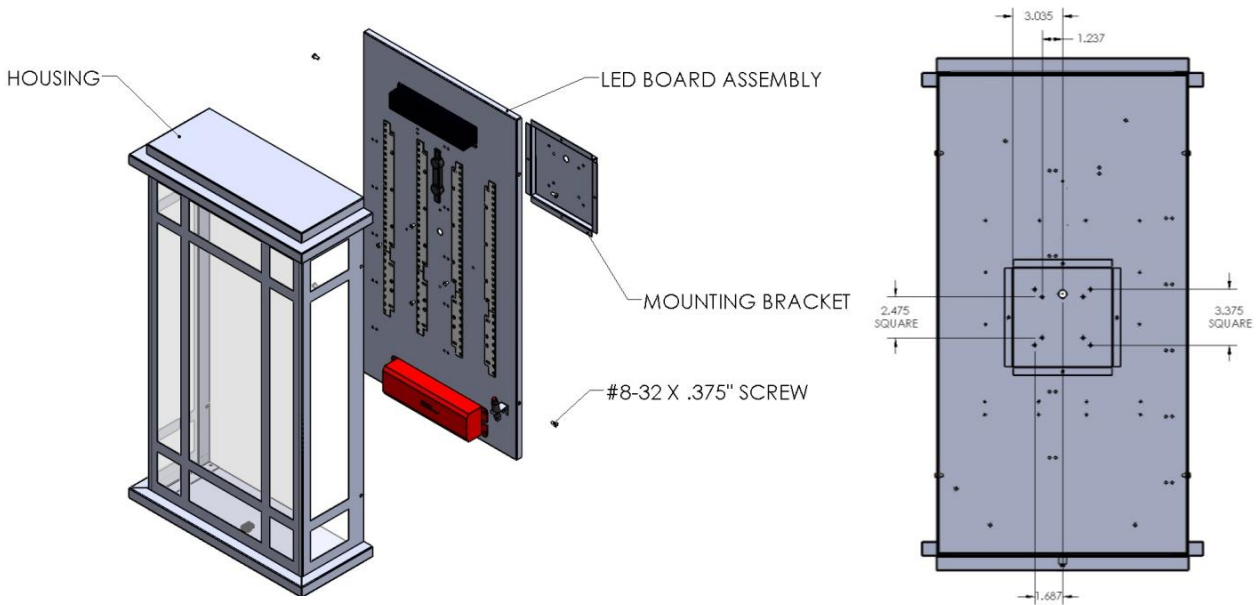

WIRING DIAGRAM

