

HERITAGE OVAL EYE LED

Architectural Outdoor



PROJECT:	
TYPE:	
PO#:	QTY:
COMMENTS:	

FEATURES

- Die-Cast, Marine Grade Aluminum Housing
- Injection Molded Polycarbonate Fascia w/ Weep Holes
- Translucent White Injection Molded
- UV-Stabilizing Polycarbonate Diffuser
- 0.040" Aluminum Reflector Plate w/ Hi-Reflectance White Powder Coat Finish
- Extruded, EPMD Ribbed / Foam Rubber Gasketing
- Junction Box Pattern on Housing For Easy Mounting
- Thermal Compensation Technology Ensures Longer LED Lifetime, Which is Ideal, For Fixtures Being Placed in Area w/ Fluctuating or Higher Ambient Temperatures
- 100V - 277V
- Surge Protector
- CSA Listed Wet Location For Wall or Ceiling Mount

LINE DRAWING

LINE DRAWING NOT TO SCALE

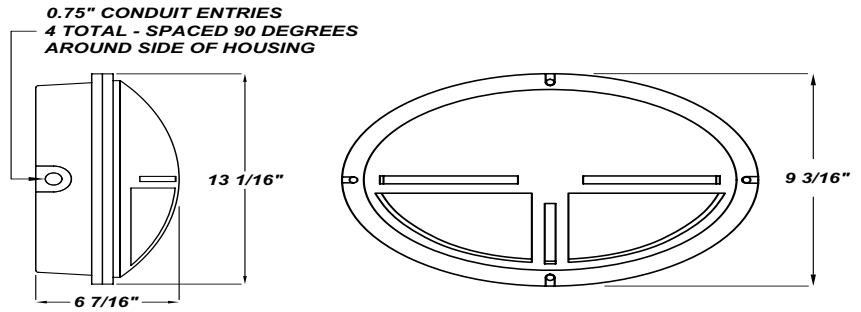

FINISHES

For RAL Colors
& Custom
Match -
Contact Teron
Lighting Inc.

HERITAGE OVAL EYE LED

Architectural Outdoor



Fixture Core

PROJECT:	
TYPE:	
PO#:	QTY:
COMMENTS:	

PRODUCT CODE	SOURCE/WATTAGE	VOLTAGE	DIMMING DRIVER
HRO - Heritage Oval	12.3 - (4) 3.066W ThermAdjust LED Strips L24.5 - (8) 3.066W ThermAdjust LED Strips	100 - 277V (50 / 60Hz)	Not Applicable
ORDER INFO			
HRO	L12.3	100 - 277V	Not Applicable

Example ^ (may not represent a manufacturable product)

Aesthetics & Options

TRIM	FINISH	COLOR TEMP	OPTIONS
EYE	BK - Matte Black BZ - Matte Bronze WH - Matte White TI - Matte Titanium	27K - 2700K Color Temp 30K - 3000K Color Temp 35K - 3500K Color Temp 40K - 4000K Color Temp 50K - 5000K Color Temp	F - Fused PCL120 - 120V Photocell PCL277 - 277V Photocell TP - Tamper Resistant Screws
ORDER INFO			
EYE	BK	27K	F

Example ^ (may not represent a manufacturable product)

PROD	SOURCE	30K SPECS				
HRO	L12.3	<ul style="list-style-type: none"> 30K - 3000K Color Temp 1264 LED Source Lumens 102.8 LED Source Lumens Per Watt 				
	L24.5	<ul style="list-style-type: none"> 30K - 3000K Color Temp 2528 LED Source Lumens 103.2 LED Source Lumens Per Watt 				

REPLACEMENT PART	PART NO	NOTES
White Ribbed Polycarbonate Diffuser	3408660	
Frosted Ribbed Polycarbonate Diffuser	3408662	

Don't see the configuration you are looking for?
Call us today at (513) 858-6004



TERONLIGHTING.COM
33 DONALD DR, FAIRFIELD, OH 45014
P: 513.858.6004 F: 513.858.6038
E: SALES@TERONLIGHT.COM



We reserve the right to revise the design components of any product due to parts availability or change in UL standards, without assuming any obligation or liability to modify any products previously manufactured, and without notice.