

INSTALLATION & MAINTENANCE INSTRUCTIONS

APEX S
PHOENIX
CREST HILLS
DALY S
PRECEPT
DORAL
NIKE S
JAVELIN S

HUNTINGTON
KEYSTONE
LEHMAN
OAK HILLS
OPEN
CREST HILLS ADA
CYPRESS POINT
TEMPEST S

O'MEARA
TITLEIST
WEST CHESTER
WESTHAMPTON
WILLIAMSPORT
DORAL ADA
ECLIPSE S
DECO

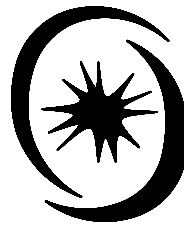

TLI
Teron Lighting, Inc.

Echelon
COLLECTION

TERON
SERIES

76003

INSTALLATION

- 1] Remove any excess packing from the fixture.
- 2] Connect the fixture leads to the supply leads. TLI stipulates the Black as Line; White as Common; Bare/Green as Ground.
- 3] For the nipple mount, attach the crossbar(A) to the j-box. Screw the nipple into the cross bar. Place the center hole(B) over the nipple, and install the brass cap provided in the mount kit bag.
- 4] Check the re-lamp label to ensure that the lamp is the specified wattage.
- 5] Install lens where applicable.

NOTE: THIS PRODUCT MUST BE INSTALLED IN ACCORDANCE WITH THE APPLICABLE INSTALLATION CODE BY A PERSON FAMILIAR WITH THE CONSTRUCTION AND OPERATION OF THE PRODUCT AND THE HAZARDS INVOLVED.

MAINTENANCE

The lens should be cleaned once every 6 months. Repeat the above procedures in reverse to remove the lens. It must be washed in a mild soap solution. DO NOT use cleansers containing bleach. Re-assemble the fixture.

The metal portion of the fixture can be wiped clean as needed using a mild soap solution.

ATTENTION: Avoid moving any exposed wires. If any wires are accidentally disconnected, call a professional to repair.

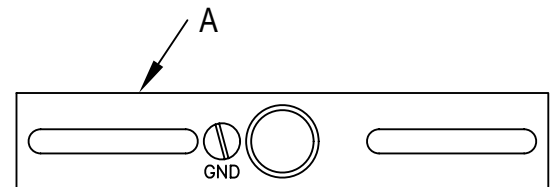
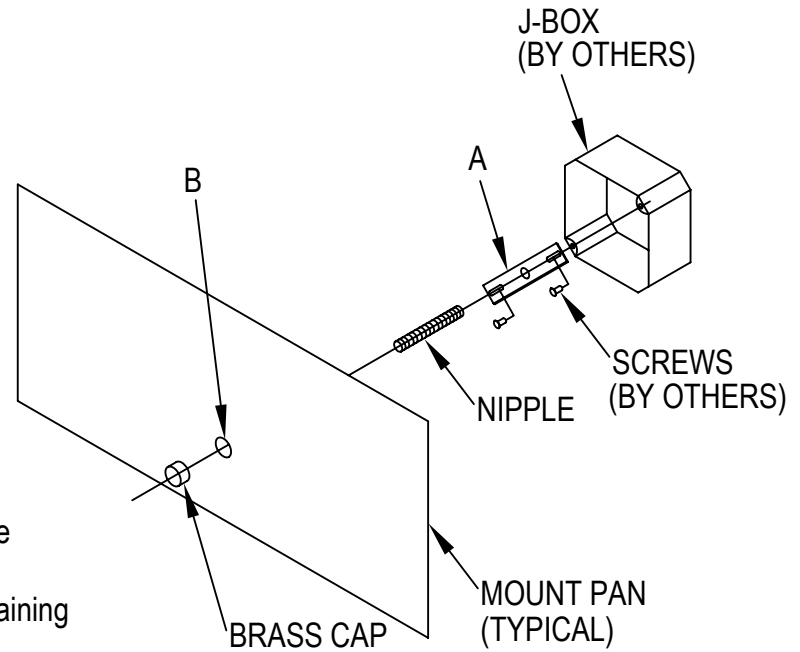

These instructions are general to the fixtures noted.
Due to the numerous options, all variations may not be covered.

Installation of an electrical luminaire must be performed by a qualified professional. The fixture must be wired in accordance to all local & national electrical codes.